

Installation manual

Poker LS II

POKER LS



230V/50HZ T5/T8
1. Power and dimensions

| Power [W] | L[mm] | Weight [kg] |
|--------------|-------|-------------|
| 1x36 | 1229 | 3 |
| 1x58 | 1529 | 3,5 |
| 2x36 | 1229 | 3,1 |
| 2x58 | 1529 | 3,6 |
| 2x1x36 | 2458 | 6 |
| 2x1x58 | 3058 | 7 |
| 2x2x36 | 2458 | 6,2 |
| 2x2x58 | 3058 | 7,2 |
| 1x28/54 | 1174 | 3 |
| 1x35/49/80 | 1474 | 3,5 |
| 2x28/54 | 1174 | 3,1 |
| 2x35/49/80 | 1474 | 3,6 |
| 2x1x28/54 | 2348 | 6 |
| 2x1x35/49/80 | 2948 | 7 |
| 2x2x28/54 | 2348 | 6,2 |
| 2x2x35/49/80 | 2948 | 7,2 |



2. Assembly

- a) remove carefully luminaire from packaging and put in safety and stable place
- b) choose the phase of reflector and connect the power wire according to signs at power cube

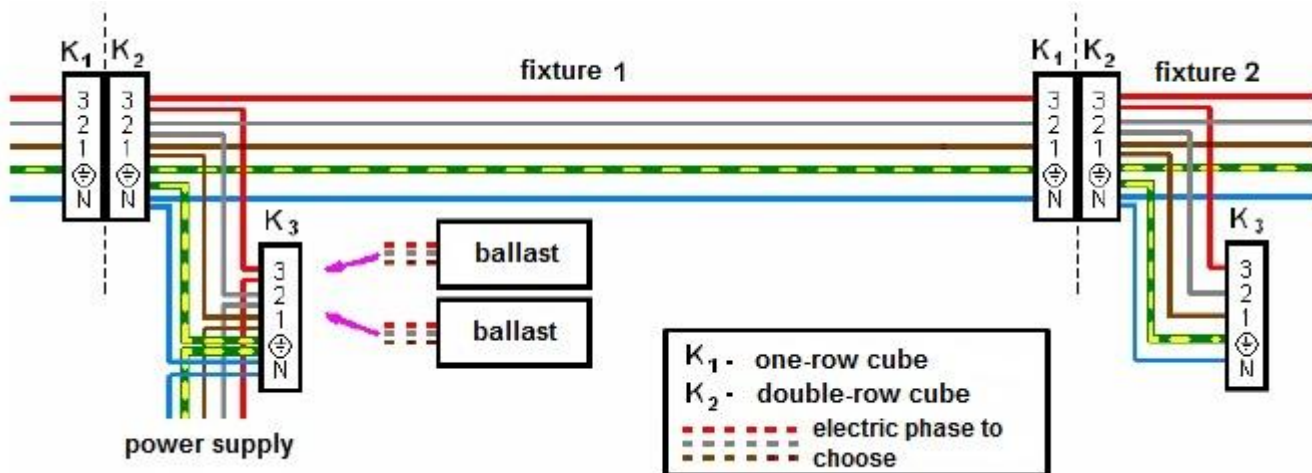

- c) connect wires of external power supply accordingly into K3 cube

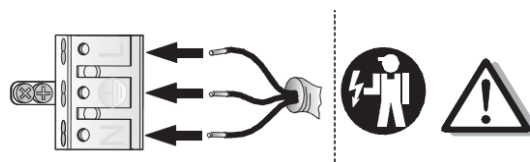

d) assembly of fittings and end caps:

- in first luminaire of the line put the closing plate and screw from the upper side with screws
- then put fixings (linear connectors) into the luminaires so they join two side reflectors with eight screws
- electrical connection between side luminaire are made with use of male and female cubes

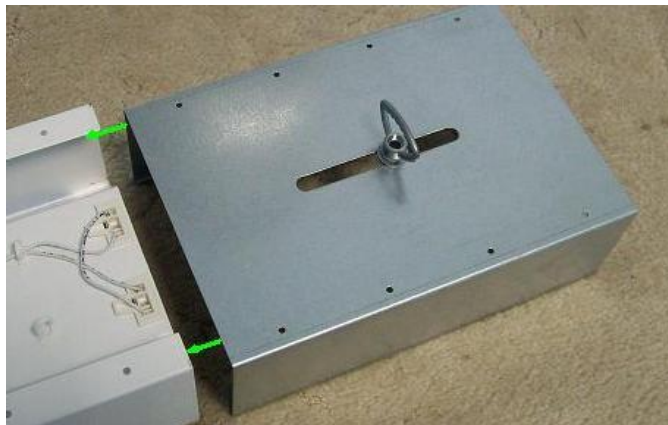
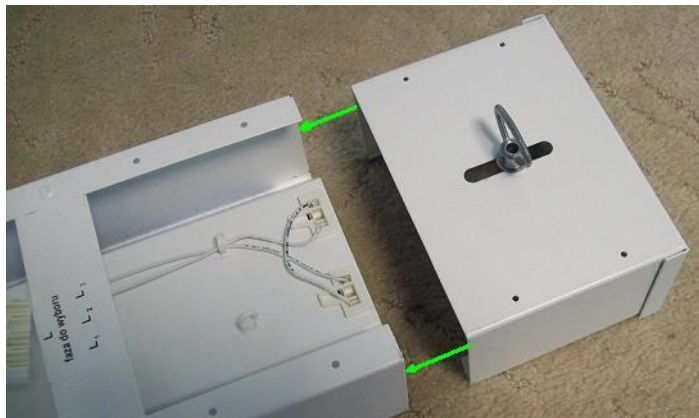

e) fluorescent lamp mounting:

- lamps of correct power put to the luminaire
- rotate fluorescent lamp 90 degrees

f) suspension regulation:

- height suspension regulation is done with handle move on the linear connectors and end caps

!! Gauge of the suspension equals the length of luminaire it is mounted on. All linear connectors and closing plates must be suspended !!

- balance the luminaire by regulation of chain to the next hole of handle

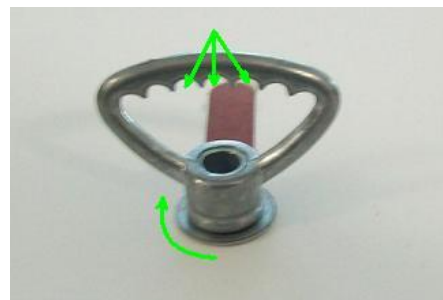

3. Important warnings:

The manufacturer cannot be considered liable for any damages deriving from improper, wrong and unreasonable use of the fitting.

Luminaries may be installed by qualified personnel only.

Any manipulation inside the luminaire when power supply is on causes the risk of electric shock.

Manufacturer is not responsible for any flaws caused by avoid using this manual.

Manufacturer reserves a right to change the construction of the product.

Do not assembly in places without air circulation.

To guarantee safety of luminaire functions, please assembly according to instruction.



The European Directive 2002/96/EC on waste electrical and electronic equipment, requires that electric and electronic devices must be disposed of in the normal household waste. The crossed out wheeled bin is reproduced in order to remember obligations towards separately collection. For correct disposal, please use authorized waste disposal facilities or returned to the distributor at the date a new lighting fitting is purchased. Lamps, if disposed together with the lighting fitting, shall not be broken up since they contain substances which are highly polluting for the environment. Unauthorized disposal of the foregoing waste material is punishable by law. More details of directive available at: <http://www.gios.gov.pl>

