

Standards

EN 55015
EN 61000-3-2
EN 61000-3-3
EN 61347-1
EN 61347-2-13
EN 61547
EN 62384

Glow wire test

according to EN 60598-1 with increased temperature of 850 °C passed.

Overload protection

If the output voltage range is exceeded the LED control gear reduces the LED output current. After elimination of the overload the nominal operation is restored automatically.

Short-circuit behaviour

In case of a short circuit on the secondary side (LED) the LED control gear switches into hic-cup mode. After the removal of the short-circuit fault the LED control gear will recover automatically.

No-load operation

The LED control gear works in constant current mode. In no-load operation there is the max. output voltage at the output (see page 1).

Installation instructions

Note the requirements set out in the document LED_driver_installation_advise.pdf (<http://www.tridonic.com/com/en/technical-docs.asp>).

Hot plug-in or secondary switching of LEDs is not permitted and may cause a very high current to the LEDs.

Maximum loading of automatic circuit breakers

Automatic circuit breaker type	C10	C13	C16	C20	B10	B13	B16	B20	Inrush current	
									I_{max}	Time
Installation Ø	1.5 mm ²	1.5 mm ²	1.5 mm ²	2.5 mm ²	1.5 mm ²	1.5 mm ²	1.5 mm ²	2.5 mm ²		
LCBU 10W 12V BASIC phase-cut SR	50	65	80	100	50	65	80	100	1.7 A	40 µs

Wiring diagram

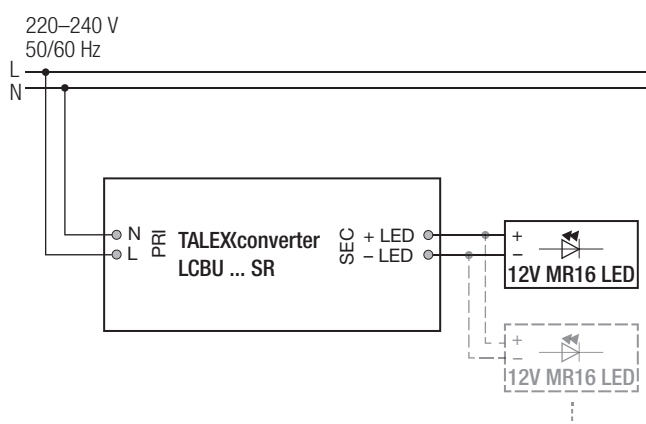

Wiring type and cross section

The wiring can be in stranded wires with ferrules or solid. For perfect function of the cage clamp terminals the strip length should be 4 – 5 mm for the input terminal.

The max. torque at the clamping screw (M3) is 0.2 Nm.

Input terminal (D2)

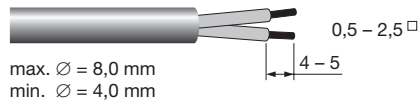

Output terminal (D1)

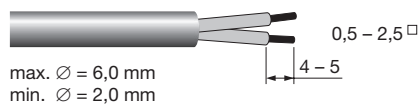

To get a proper working strain relief it is recommended that the cable jacket diameter of the side D2 is compared to the side D1 terminal according to the value table. (This can vary if the used cable jacket material varies from side D2 to D1 in pinching property).

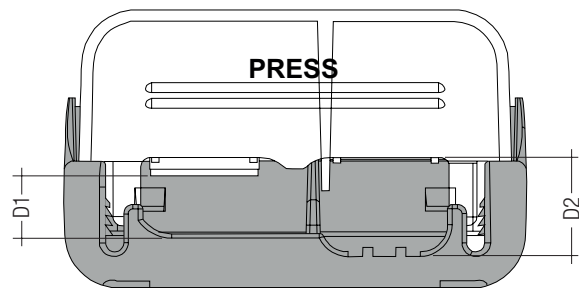

Depending on the used flaps of the terminal following cable jacket diameter difference between the side D2 and D1 terminals is recommended:

Side D1		Side D2		Difference D2 - D1
With flap	Without flap	With flap	Without flap	
x	–	–	x	4 mm
–	x	–	x	2 mm
x	–	x	–	2 mm
–	x	x	–	0 mm

Wiring instructions

The secondary leads should be separated from the mains connections and wiring for good EMC performance.

Maximum lead length on secondary side is 3 x 2 m (parallel wiring of 12 V modules). For a good EMC performance keep the the LED wiring as short as possible.

Isolation and electric strength testing of luminaires

Electronic devices can be damaged by high voltage. This has to be considered during the routine testing of the luminaires in production.

According to IEC 60598-1 Annex Q (informative only!) or ENEC 303-Annex A, each luminaire should be submitted to an isolation test with 500 V_{DC} for 1 second. This test voltage should be connected between the interconnected phase and neutral terminals and the earth terminal.

The isolation resistance must be at least 2 MΩ.

As an alternative, IEC 60598-1 Annex Q describes a test of the electrical strength with 1500 V_{AC} (or 1.414 x 1500 V_{DC}). To avoid damage to the electronic devices this test must not be conducted.

Additional information

Additional technical information at www.tridonic.com → Technical Data

Guarantee conditions at www.tridonic.com → Services

No warranty if device was opened.