

Flash

Installation manual Flash

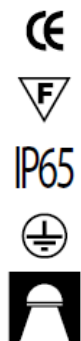

230V/50HZ HST, HIT

1. Power and weight

Power	Weight (kg)
150W	8kg
250W	8kg
400W	8,5kg

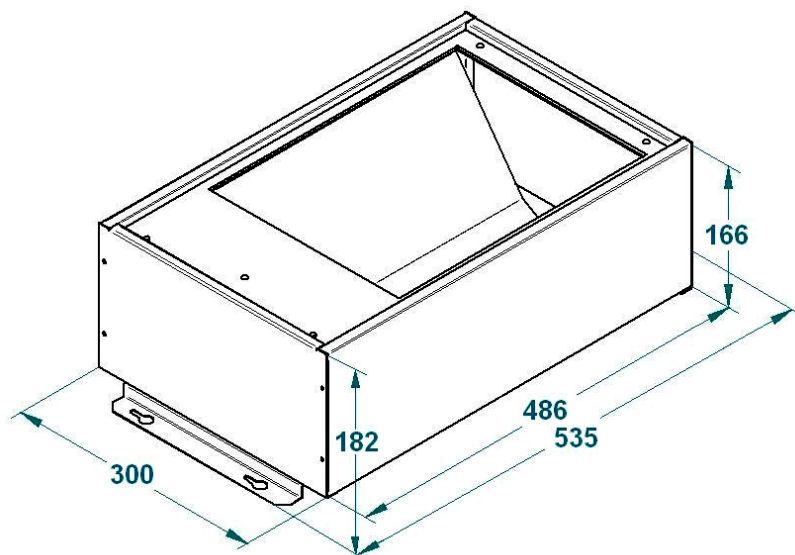

2. Assembly

- a) remove carefully fixture from packaging and put in safety and stable place (table or floor)
- b) make 4 screws off unchain and remove the glass

c) power connection

- take power cable through the sealing of the hole in the base
- connect wires according to label at the base

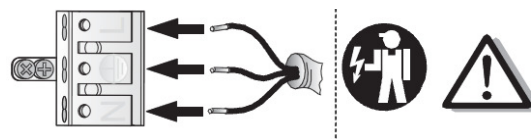

d) fixing the fixture to the ceiling:

- fixture is mounted to the ceiling with holes of 6,5mm length

e) fixing the fixture in the suspension ceiling:

- dimensions of the assembly hole: **520x340**
- mount the fixture to the construction of ceiling
- pull the springs on the masking frame and mount it to the ceiling hole

f) put the light source

- g) assembly chain protecting the glass
- h) place the glass and screw up

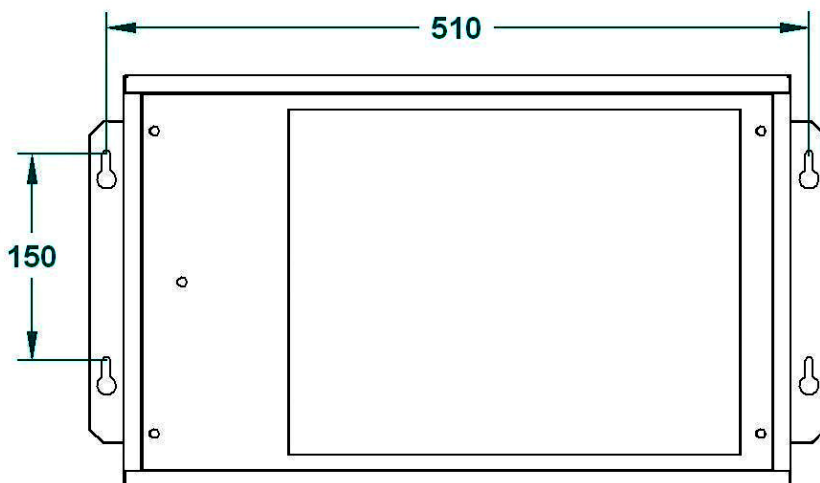

3. Important warnings:

The manufacturer cannot be considered liable for any damages deriving from improper, wrong and unreasonable use of the fitting.

Luminaries may be installed by qualified personnel only.

Any manipulation inside the luminaire when power supply is on causes the risk of electric shock.

Manufacturer is not responsible for any flaws caused by avoid using this manual.

Manufacturer reserves a right to change the construction of the product.

Do not assembly in places without air circulation.

To guarantee safety of fixture functions, please assembly according to instruction.



The European Directive 2002/96/EC on waste electrical and electronic equipment, requires that electric and electronic devices must be disposed of in the normal household waste. The crossed out wheeled bin is reproduced in order to remember obligations towards separately collection. For correct disposal, please use authorized waste disposal facilities or returned to the distributor at the date a new lighting fitting is purchased. Lamps, if disposed together with the lighting fitting, shall not be broken up since they contain substances which are highly polluting for the environment. Unauthorized disposal of the foregoing waste material is punishable by law. More details of directive available at: <http://www.gios.gov.pl>

