



TALEXconverter 0025 K210 24 V one4all LCU indoor IP20

Product description

- 1-channel one4all LED control gear
- For 24 V LED modules
- Dimming range 1 to 100 %
- switchDIM-MEMORY
- Short-circuit protection with automatic restart
- DC supply possible
- Rapid installation of cable clamp and terminal cover, no tool required
- Overtemperature protection
- 1 addressable and dimmable PWM output channel and 1 fixed 24 V output channel
- Cross-section of connecting cable: 2.5 mm²
- Connecting cable, supply side: H03VV-F, H05VV-F
- PWM signal output: 24 V DC
- Load range: 0.1 – 25 W
- Nominal life-time up to 50,000 h
- 5-year guarantee

Technical data

Rated supply voltage	230 V
Input voltage, AC	198 – 254 V
Input voltage, DC	200 – 240 (160) V ^①
Rated current (at 230 V 50 Hz)	0.13 A
Mains frequency	0 / 50 / 60 Hz
PWM frequency	1 kHz
Efficiency	> 82 %
Power factor at full load	0.94C
Max. input power	31 W
Output power	25 W (max. sum of fixed and dimmable output)
Max. cable length secondary	Cable length is limited by voltage drop of 1 V
Dimming	DSI, DALI, switchDIM – single momentary-action switch
Ambient temperature t _a	-25 ... +45 °C
Max. casing temperature t _c	75 °C
Weight	0.155 kg
Dimensions LxWxH	167 x 42 x 31 mm
Hole spacing D	143 – 148 mm

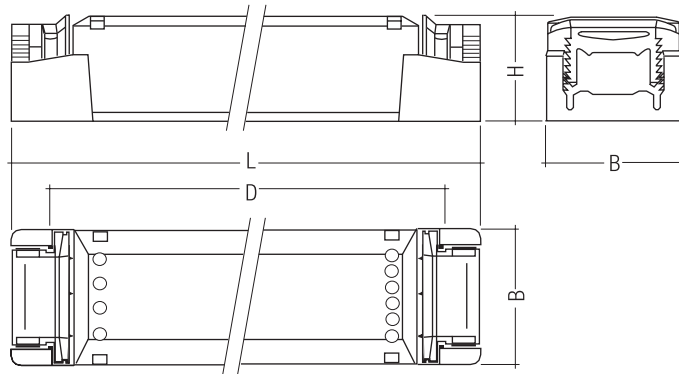

Ordering data

Secondary voltage DC	Type	Article number
24 V	0025 K210 24 V	28000858

Packaging: 20 pieces/carton

^① After power up with higher voltage, the device will work with a reduced voltage as specified above.



Standards, page 2

Installation examples, page 2

Standards

- EN 55015
- EN 61000-3-2
- EN 61000-3-3
- EN 61347-1
- EN 61347-2-13
- EN 61547
- EN 62384

switchDIM (with memory function)

Integrated switchDIM function allows a direct connection of a push to make switch for dimming and switching.

Brief push (< 0.6 s) switches LED control gear ON and OFF. The LED control gears switch-ON at light level set at switch-OFF.

When the push to make switch is held, LED modules are dimmed. After repush the LED modules are dimmed in the opposite direction.

In installations with LED control gears with different dimming levels or opposite dimming directions (e.g. after a system extension), all LED control gears can be synchronized to 50 % dimming level by a 10 s push.

Use of push to make switch with indicator lamp is not permitted.

switchDIM is a very simple tool for controlling ballasts with conventional momentary-action switches or motion sensors.

To ensure correct operation a sinusoidal mains voltage with a frequency of 50 or 60 Hz is required at the control input.

Special attention must be paid to achieving clear zero crossings. Serious mains faults may impair the operation of switchDIM.

Wiring

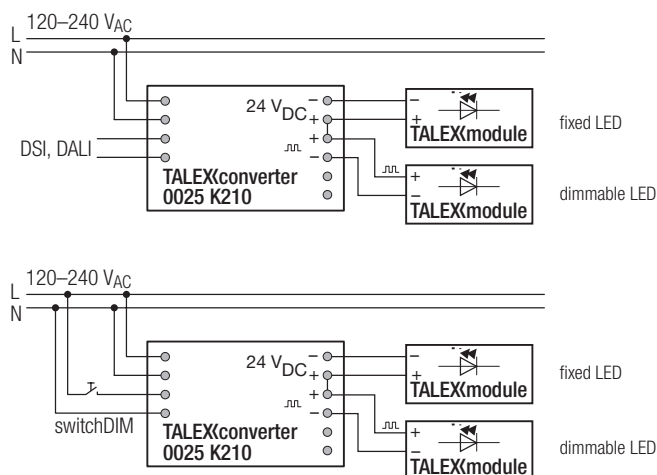

Maximum loading of automatic circuit breakers

Automatic circuit breaker type	C10	C13	C16	C20	B10	B13	B16	B20
Installation Ø	1.5 mm ²	1.5 mm ²	1.5 mm ²	2.5 mm ²	1.5 mm ²	1.5 mm ²	1.5 mm ²	2.5 mm ²
0025 K210 24 V	60	80	100	125	60	80	100	125

Expected life-time

Type	ta	35 °C	40 °C	45 °C
		tc	65 °C	70 °C
0025 K210 24 V	life-time	100,000 h	70,000 h	50,000 h

Isolation and electric strength testing of luminaires

Electronic devices can be damaged by high voltage. This has to be considered during the routine testing of the luminaires in production.

According to IEC 60598-1 Annex Q (informative only) or ENEC 303-Annex A, each luminaire should be submitted to an isolation test with 500 V_{DC} for 1 second. This test voltage should be connected between the interconnected phase and neutral terminals and the earth terminal.

The isolation resistance must be at least 2 MΩ.

As an alternative, IEC 60598-1 Annex Q describes a test of the electrical strength with 1500 V_{AC} (or 1.414 x 1500 V_{DC}). To avoid damage to the electronic devices this test must not be conducted.

Additional information

Additional technical information at www.tridonic.com → Technical Data

Guarantee conditions at www.tridonic.com → Services

No warranty if device was opened.