

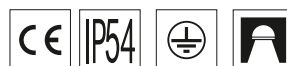

## Modena Mini



Modern plafond Modena Mini is an extension of Modena family of luminaires. Highly aesthetic and characteristic for great parameters: resistance to external conditions and UV rays with IP54 degree of protection. Possibility of application of motion sensor, day light sensor or emergency module.

**Materials:** white version: base and diffuser made of white UV proof polycarbonate, grey version: grey base and white diffuser made of UV proof polycarbonate

**Installation:** ceiling mounted, wall mounted

**Power:** 230 V

### ELECTRICAL DATA

Ignitor/starter	Not required
Voltage rating	230 V
SELV	No

### MECHANICAL DATA

Type of installation	Surface mounted
Housing material	Polycarbonate

### CERTIFICATES

Degree of protection (IP)	IP54
Class of protection	I
CE	Yes

### LIGHT DATA

Light distribution	Wide beam
Light distribution	DI
Class of luminaire	I

### OPTICAL DATA

Louver/shutter	OPAL
Diffuser color	White
Diffuser material	Opal/mat plastic

### MATERIALS

Product code	Light source	Lamp holder	Light source power [W]	Type of equipment	Color	Energy class	Weight [kg]
PX3004001	A60	E27	1×60	-	White	-	1.15
PX3004008	TC-TSE	E27	2×20	-	White	A	1.25
PX3004015	TC-S	2G7	2×9	EVG	White	A	1.15
PX3004022	TC-L	2G11	1×18	EVG	White	A	1.15
PX3004029	TC-L	2G12	2×18	EVG	White	A	1.15
PX3004036	TC-DE	G24q-2	1×18	EVG	White	A	1.15
PX3004043	TC-DE	G24q-2	2×18	EVG	White	A	1.15
PX3004050	TC-DE	G24q-3	1×26	EVG	White	A	1.15
PX3004057	TC-F	2G10	1×36	EVG	White	A	1.15
PX3005101	A60	E27	1×60	-	Grey	-	1.15
PX3005108	TC-TSE	E27	2×20	-	Grey	A	1.25
PX3005115	TC-S	2G7	2×9	EVG	Grey	A	1.15
PX3005122	TC-L	2G11	1×18	EVG	Grey	A	1.15
PX3005129	TC-L	2G12	2×18	EVG	Grey	A	1.15
PX3005136	TC-DE	G24q-2	1×18	EVG	Grey	A	1.15

Product code	Light source	Lamp holder	Light source power [W]	Type of equipment	Color	Energy class	Weight [kg]
PX3005143	TC-DE	G24q-2	2×18	EVG	Grey	A	1.15
PX3005150	TC-DE	G24q-3	1×26	EVG	Grey	A	1.15
PX3005157	TC-F	2G10	1×36	EVG	Grey	A	1.15

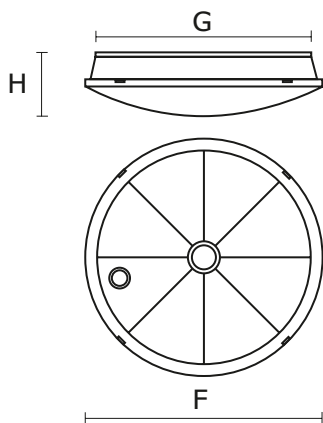

## DIMENSIONS

H [mm]	F [mm]
90	315

H = Height / Depth | F = Outer diameter

## MOUNTING HOLES

Product code	A [mm]
PX3004001	298
PX3004008	-
PX3004015	-
PX3004022	-
PX3004029	-
PX3004036	-
PX3004043	-
PX3004050	-
PX3004057	-
PX3005101	-
PX3005108	-
PX3005115	-
PX3005122	-
PX3005129	-
PX3005136	-
PX3005143	-
PX3005150	-
PX3005157	-

A = Spacing length