

Installation manual
SUN LED



230V/50HZ

Power [W]	Dimensions [mm]	Weight [kg]
45W	596x596	4,3
45W	1196x296	4,4

CE
 F
IP44/20

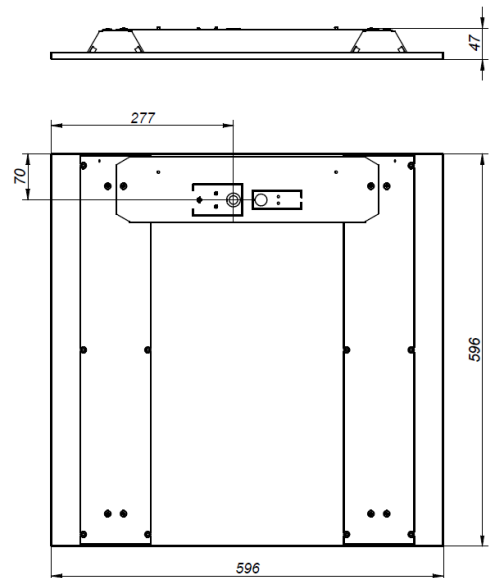
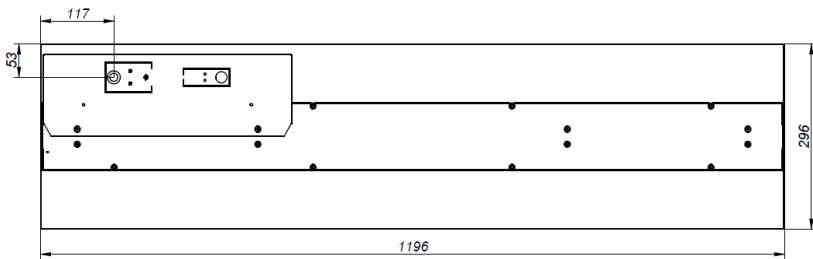

- turn off the power in the circuit in which you are going to install the luminaire;
- carefully take the luminaire out of box;
- pull the flap with a cube and put the feeding cable through the hole with a gland;
- connect the wires as shown on a cube;
- put the luminaire in the ceiling.

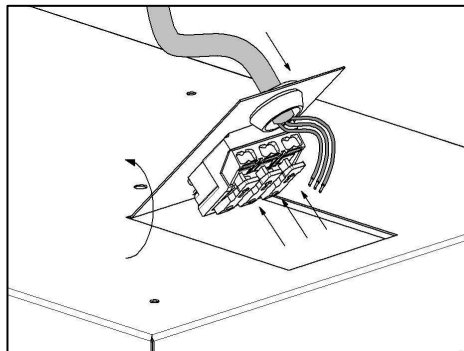
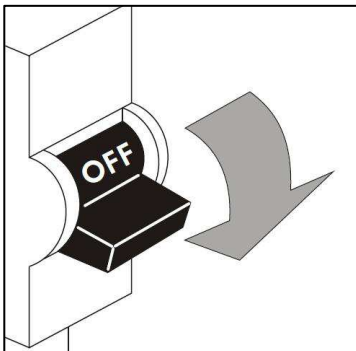

*IP44 from the front side of the fixture after installation.

Important warnings:

Do not install the luminaires in areas without an exchange of air.
 The manufacturer cannot be considered liable for any damages deriving from improper, wrong and unreasonable use of the fitting.
 Luminaries may be installed by qualified personnel only.
 Any manipulation inside the luminaire when power supply is on causes the risk of electric shock.
 Manufacturer is not responsible for any flaws caused by avoid using this manual.
 Manufacturer reserves a right to change the construction of the product.



The European Directive 2002/96/EC on waste electrical and electronic equipment, requires that electric and electronic devices must be disposed of in the normal household waste. The crossed out wheeled bin is reproduced in order to remember obligations towards separately collection. For correct disposal, please use authorized waste disposal facilities or returned to the distributor at the date a new lighting fitting is purchased. Lamps, if disposed together with the lighting fitting, shall not be broken up since they contain substances which are highly polluting for the environment. Unauthorized disposal of the foregoing waste material is punishable by law.